



**Cu-nnect Exothermic Welding  
Product Catalogue**



## Welcome to our new Cu-nnect Exothermic Welding catalogue.

Our comprehensive, competitively priced product range has been brought together for the first time, into one brochure to make purchasing and specifying so much easier.

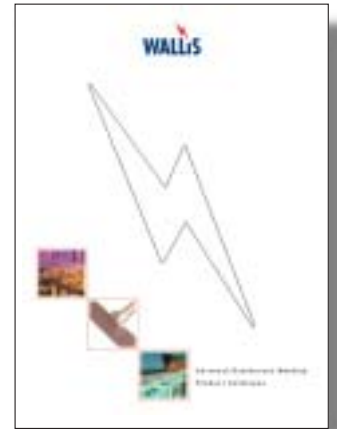

This, coupled with our rapid delivery promise, makes A. N. Wallis your first choice every time.

Our large Cu-nnect range of products is used worldwide on power stations, substations, transmission lines; petro-chemical facilities and pipelines; oil and gas facilities and sports stadia. All backed by over fifty years of A. N. Wallis experience for that extra piece of mind.

So whatever you need whether it is moulds and powders, or tools and accessories it's all here in one catalogue.

Just one phone call, fax or mouse click away.



## CONTENTS

---

<b>The Cu-nnect Exothermic Welding System</b>	<b>2 - 3</b>
<b>Connection Locator</b>	<b>4 - 5</b>
<b>Alphabetical Product Index</b>	<b>6</b>
<b>Cu-nnect Product Pages</b>	<b>7 - 29</b>
<b>Bar to Bar</b>	<b>7 - 9</b>
<b>Bar to Earth Rod</b>	<b>10 - 11</b>
<b>Bar to Steel Surface</b>	<b>12 - 13</b>
<b>Cable to Bar</b>	<b>14 - 16</b>
<b>Cable to Cable</b>	<b>17 - 20</b>
<b>Cable to Earth Rod</b>	<b>21 - 23</b>
<b>Cable to Rebar</b>	<b>24 - 26</b>
<b>Cable to Steel Surface</b>	<b>27 - 29</b>
<b>Stud to Steel Surface</b>	<b>29</b>
<b>Weld Powders</b>	<b>30</b>
<b>Moulds</b>	<b>30</b>
<b>Handle Clamps</b>	<b>31</b>
<b>Tools &amp; Accessories</b>	<b>31</b>
<b>Part Number Index</b>	<b>32</b>

## THE CU-NECT EXOTHERMIC WELDING SYSTEM

---

Cu-nect exothermic welding is a simple, economical method of making permanent, very high quality electrical connections. The process uses the high temperature reaction of copper oxide and aluminium, within a semi-permanent graphite mould, to form electrical connections mainly between copper to copper or copper to steel.

No outside source of power or heat is required when using the Cu-nect system. It is also light and completely portable, making it ideal for field use. It is a straightforward method which requires very little training in order to safely obtain a quality, maintenance free connection, therefore making it both time and cost effective.

Making a Cu-nect joint is a simple procedure which requires a mould, weld powder, handle clamp and various tools and cleaning accessories as detailed below:

7. Remove weld and clean mould carefully before making next connection.

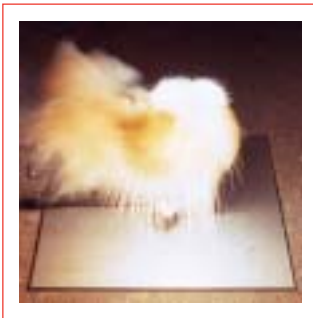

6. Reaction takes place. Wait several seconds to allow metal to solidify before opening mould.



5. Ignite starting powder using flint gun.

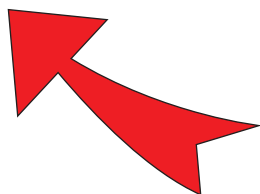

1. Position cleaned conductors in mould after ensuring mould is dry, by pre-heating or making a test joint.

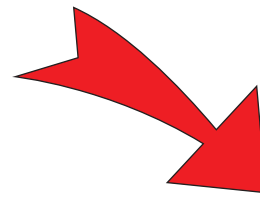

2. Lock mould with handle clamp and place metal retaining disc in bottom of mould crucible.



3. Pour weld powder into mould and place small amount of starting powder on edge of mould for easy ignition.

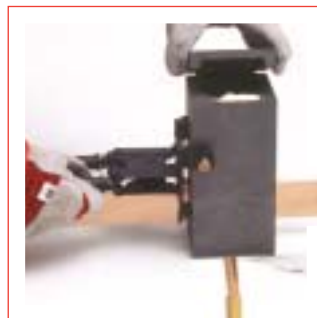
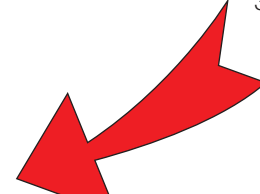

4. Close mould lid securely.

## THE CU-NNECT EXOTHERMIC WELDING SYSTEM

The Cu-nnect electrical connection is a fusion of high conductivity, high copper content alloys which produces a molecular weld. This weld has at least twice the cross-sectional area of the conductors being joined and a current-carrying capacity equal to or greater than that of the conductors, enabling it to withstand repeated fault currents. The weld will not loosen or corrode and is an integral part of the conductor.



For any additional technical advice or information contact our Sales team.

### Using This Catalogue

This catalogue is designed to be as easy to use as possible. To help find the product you need, there is an alphabetical index, part number index and product locator. Every product featured has its own application drawing and product table.

Just phone, fax or e-mail us with your enquiries.

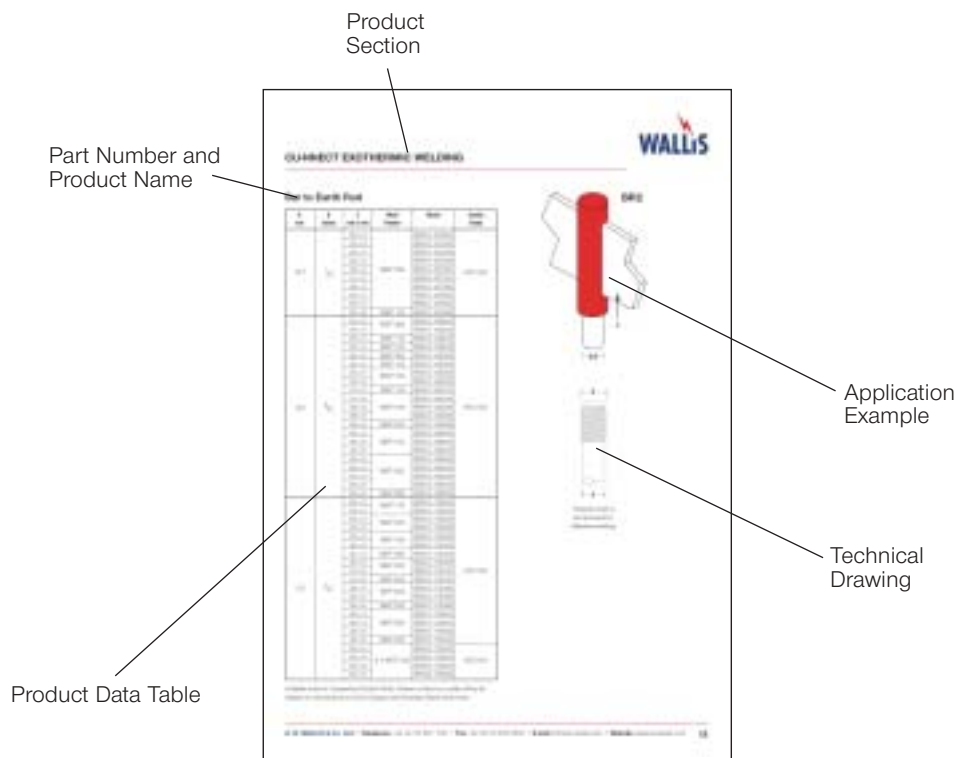

## Bar to Bar

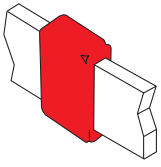

BB1 - Page 7

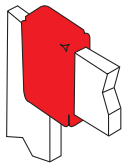

BB2 - Page 7

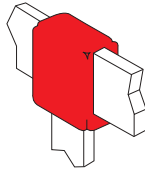

BB3 - Page 8

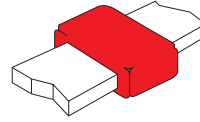

BB7 - Page 8

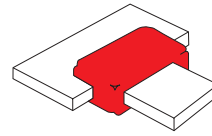

BB14 - Page 9

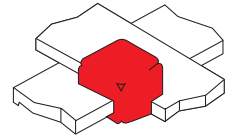

BB41 - Page 9

## Bar to Earth Rod

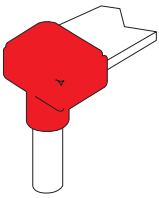

BR1 - Page 10

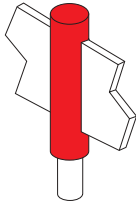

BR2 - Page 11

## Bar to Steel Surface

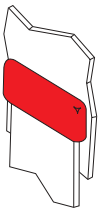

BS1 - Page 12

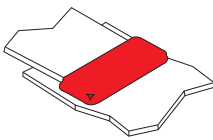

BS2 - Page 12

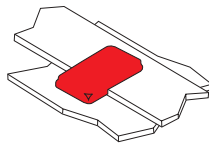

BS3 - Page 13

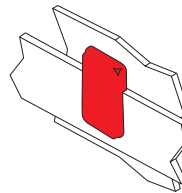

BS4 - Page 13

## Cable to Bar

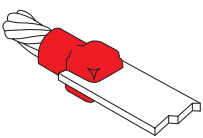

CB1 - Page 14

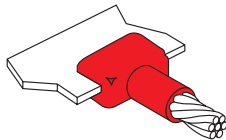

CB4 - Page 15

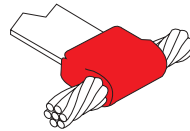

CB5 - Page 16

## Cable to Cable

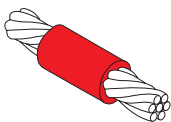

CC1 - Page 17

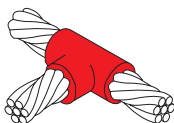

CC2 - Page 17 & 18

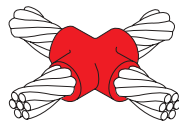

CC4 - Page 18

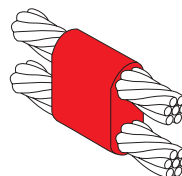

CC7 - Page 19

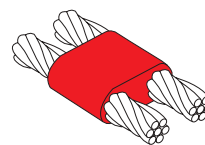

CC14 - Page 20

## CONNECTION LOCATOR

### Cable to Earth Rod

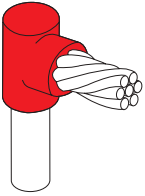

CR1 - Page 21

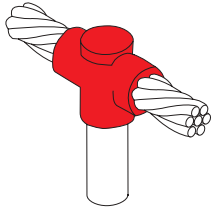

CR2 - Page 22

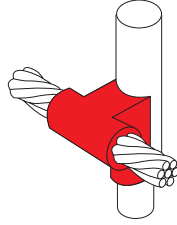

CR3 - Page 23

### Cable to Rebar

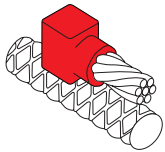

CRE1 - Page 24

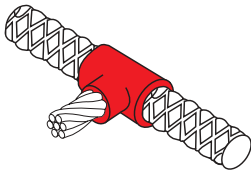

CRE2 - Page 24 & 25

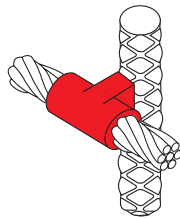

CRE3 - Page 25



CRE6 - Page 26

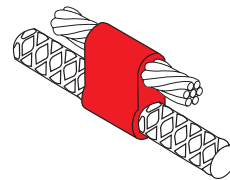

CRE17 - Page 26

### Cable to Steel Surface

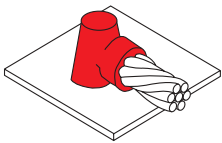

CS1 - Page 27

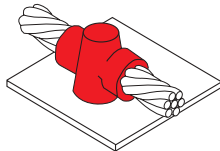

CS2 - Page 27

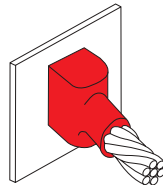

CS3 - Page 27

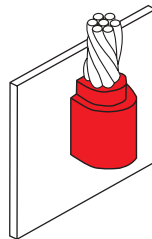

CS7 - Page 28

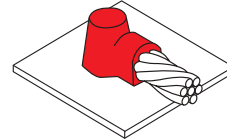

CS8 - Page 28

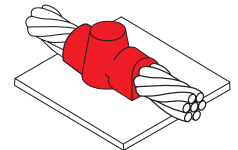

CS9 - Page 28

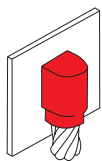

CS25 - Page 29

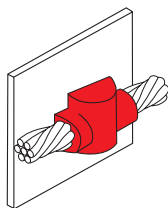

CS27 - Page 29

### Stud to Steel Surface

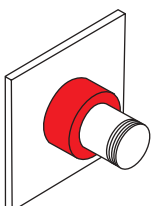

RS1 - Page 29

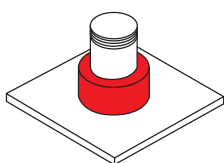

RS2 - Page 29

**Your connection not shown?  
Then contact our sales office on  
Tel +44 (0) 115 927 1721  
or e-mail [info@an-wallis.com](mailto:info@an-wallis.com)**

**A**

Accessories 2, 31

**B**

Bar to  
Bar Connections 7-9  
Earth Rod Connections 10-11  
Steel Surface Connections 12-13  
Brush for cleaning  
Cable 31  
Mould 31  
Tape 31  
Butane Torch 31

**C**

Cable Cleaning Brush 31  
Cable to  
Bar Connections 14-16  
Cable Connections 17-20  
Earth Rod Connections 21-23  
Rebar Connections 24-26  
Steel Surface Connections 27-29  
Cartridge 30  
Ceramic Packing 24-26, 31  
Cleaning  
Brush for Cable 31  
Brush for Mould 31  
Brush for Tape 31  
Scraper for Mould 31  
Conductors 2  
Copperbond Earth Rods 10-11, 21-23

**D**

Disc 2  
Disc Container 31  
Duxseal Sealing Compound 24-26, 31

**E**

Earth Rod to  
Bar Connections 10-11  
Cable Connections 21-23  
Earth Rods  
Copperbond 10-11, 21-23  
Solid Copper 10-11, 21-23  
Stainless Steel 10-11, 21-23

**F**

Flint Gun 31  
Flints 31

**G**

Graphite Mould 2, 30

**H**

Handle Clamps 2, 31

**I**

Ignitor Gun 2, 31

**M**

Mould  
Clamp 2, 31  
Cleaning Brush 31  
Cleaning Scraper 31  
Graphite 2, 31  
Scraper 31

**P**

Packing 24-26, 31  
Powder  
Starting 2, 30  
Weld 2, 30  
Weld Metal 2, 30

**R**

Rebar to Cable Connections 24-26  
Retaining Disc 2, 30

**S**

Scraper 31  
Solid Copper Earth Rods 10-11, 21-23  
Stainless Steel Earth Rods 10-11, 21-23  
Starting Powder 2, 30  
Steel Surface to  
Bar Connections 12-13  
Cable Connections 27-29  
Stud Connections 29  
Stud to Steel Surface Connections 29

**T**

Tape Cleaning Brush 31  
Torch 31  
Toolbox 31  
Toolkit 31  
Tools 2, 31

**W**

Weld  
Metal Powder 2, 30  
Powder 2, 30  
Welding  
Accessories 2, 31  
Toolbox 31



## CU-NNECT EXOTHERMIC WELDING

### BB1 - Bar to Bar

A mm x mm	Weld Powder	Mould	Handle Clamp	
20 x 3	WEP 045	BB1-C-203	HCC 001	
25 x 3	WEP 065	BB1-C-253		
25 x 4	WEP 090	BB1-C-254		
25 x 6	WEP 150	BB1-C-256		
30 x 2	WEP 065	BB1-C-302		
30 x 3	WEP 090	BB1-C-303		
30 x 4	WEP 115	BB1-C-304		
30 x 5		BB1-C-305		
31 x 3	WEP 065	BB1-C-313		
31 x 6	WEP 115	BB1-C-316		
38 x 3	WEP 150	BB1-C-383		
38 x 5		BB1-C-385		
38 x 6	WEP 200	BB1-C-386		
40 x 3	WEP 115	BB1-C-403		
40 x 4	WEP 150	BB1-C-404		
40 x 5		BB1-C-405		
40 x 6	WEP 200	BB1-C-406		
50 x 3	WEP 150	BB1-C-503		
50 x 4	WEP 200	BB1-C-504		
50 x 5	WEP 200	BB1-C-505		
50 x 6	WEP 250	BB1-C-506		
50 x 8	2 x WEP 150	BB1-D-508		HCD 001

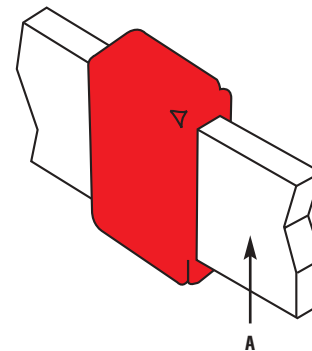

### BB2 - Bar to Bar

A mm x mm	B mm x mm	Weld Powder	Mould	Handle Clamp	
20 x 3	20 x 3	WEP 045	BB2-C-203203	HCC 001	
25 x 3	25 x 3	WEP 065	BB2-C-253253		
25 x 4	25 x 4	WEP 090	BB2-C-254254		
25 x 6	25 x 6	WEP 115	BB2-C-256256		
30 x 2	30 x 2	WEP 065	BB2-C-302302		
30 x 3	30 x 3	WEP 090	BB2-C-303303		
30 x 4	30 x 4	WEP 115	BB2-C-304304		
30 x 5	30 x 5		BB2-C-305305		
31 x 3	31 x 3	WEP 090	BB2-C-313313		
31 x 6	31 x 6	WEP 150	BB2-C-316316		
38 x 3	38 x 3	WEP 115	BB2-C-383383		
38 x 5	38 x 5	WEP 150	BB2-C-385385		
38 x 6	38 x 6	WEP 200	BB2-C-386386		
40 x 3	40 x 3	WEP 115	BB2-C-403403		
40 x 4	40 x 4	WEP 150	BB2-C-404404		
40 x 5	40 x 5		BB2-C-405405		
40 x 6	40 x 6	WEP 200	BB2-C-406406		
50 x 3	50 x 3	WEP 090	BB2-C-503503		
50 x 4	50 x 4	WEP 150	BB2-C-504504		
50 x 5	50 x 5	WEP 200	BB2-C-505505		
50 x 6	50 x 6	WEP 250	BB2-C-506506		
50 x 8	50 x 8	2 x WEP 150	BB2-D-508508		HCD 001

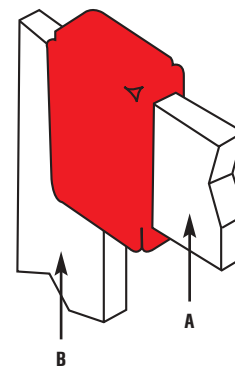

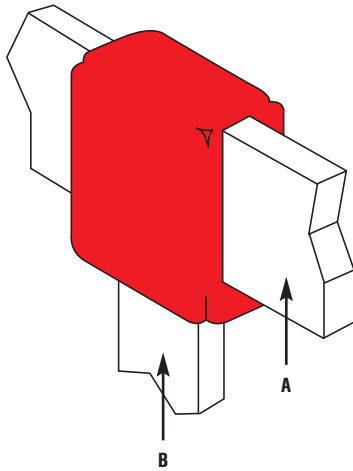

## BB3 - Bar to Bar

A mm x mm	B mm x mm	Weld Powder	Mould	Handle Clamp
20 x 3	20 x 3	WEP 065	BB3-C-203203	HCC 001
25 x 3	25 x 3		BB3-C-253253	
25 x 4	25 x 4	WEP 090	BB3-C-254254	
25 x 6	25 x 6	WEP 150	BB3-C-256256	
30 x 2	30 x 2	WEP 065	BB3-C-302302	
30 x 3	30 x 3	WEP 090	BB3-C-303303	
30 x 4	30 x 4	WEP 115	BB3-C-304304	
30 x 5	30 x 5		BB3-C-305305	
31 x 3	31 x 3		BB3-C-313313	
31 x 6	31 x 6	WEP 200	BB3-C-316316	
38 x 3	38 x 3	WEP 115	BB3-C-383383	
38 x 5	38 x 5	WEP 150	BB3-C-385385	
38 x 6	38 x 6	WEP 200	BB3-C-386386	
40 x 3	40 x 3	WEP 115	BB3-C-403403	
40 x 4	40 x 4	WEP 150	BB3-C-404404	
40 x 5	40 x 5		BB3-C-405405	
40 x 6	40 x 6	WEP 200	BB3-C-406406	
50 x 3	50 x 3		BB3-C-503503	
50 x 4	50 x 4		BB3-C-504504	
50 x 5	50 x 5		BB3-C-505505	
50 x 6	50 x 6	WEP 250	BB3-C-506506	
50 x 8	50 x 8	2 x WEP 150	BB3-D-508508	HCD 001

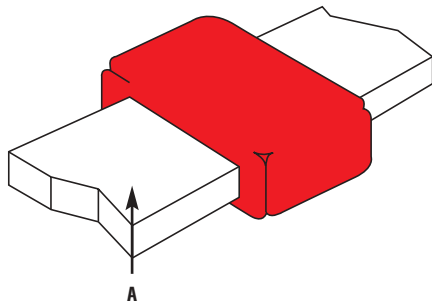

## BB7 - Bar to Bar

A mm x mm	Weld Powder	Mould	Handle Clamp
20 x 3	WEP 045	BB7-C-203	HCC 001
25 x 3	WEP 065	BB7-C-253	
25 x 4	WEP 090	BB7-C-254	
25 x 6	WEP 115	BB7-C-256	
30 x 2	WEP 065	BB7-C-302	
30 x 3		BB7-C-303	
30 x 4	WEP 090	BB7-C-304	
30 x 5	WEP 115	BB7-C-305	
31 x 3	WEP 065	BB7-C-313	
31 x 6	WEP 150	BB7-C-316	
38 x 3	WEP 090	BB7-C-383	
38 x 5	WEP 150	BB7-C-385	
38 x 6	WEP 200	BB7-C-386	
40 x 3	WEP 090	BB7-C-403	
40 x 4	WEP 115	BB7-C-404	
40 x 5	WEP 150	BB7-C-405	
40 x 6	WEP 200	BB7-C-406	
50 x 3	WEP 150	BB7-D-503	
50 x 4	WEP 200	BB7-D-504	
50 x 5		BB7-D-505	
50 x 6	WEP 250	BB7-D-506	
50 x 8	2 x WEP 150	BB7-D-508	HCD 001

## CU-NECT EXOTHERMIC WELDING

### BB14 - Bar to Bar

A mm x mm	B mm x mm	Weld Powder	Mould	Handle Clamp	
20 x 3	20 x 3	WEP 045	BB14-C-203203	HCC 001	
25 x 3	25 x 3	WEP 065	BB14-C-253253		
25 x 4	25 x 4	WEP 090	BB14-C-254254		
25 x 6	25 x 6	WEP 115	BB14-C-256256		
30 x 2	30 x 2	WEP 065	BB14-C-302302		
30 x 3	30 x 3		BB14-C-303303		
30 x 4	30 x 4	WEP 090	BB14-C-304304		
30 x 5	30 x 5	WEP 115	BB14-C-305305		
31 x 3	31 x 3	WEP 090	BB14-C-313313		
31 x 6	31 x 6	WEP 150	BB14-C-316316		
38 x 3	38 x 3	WEP 090	BB14-C-383383		
38 x 5	38 x 5	WEP 150	BB14-C-385385		
38 x 6	38 x 6	WEP 200	BB14-C-386386		
40 x 3	40 x 3	WEP 090	BB14-C-403403		
40 x 4	40 x 4	WEP 115	BB14-C-404404		
40 x 5	40 x 5	WEP 150	BB14-C-405405		
40 x 6	40 x 6	WEP 200	BB14-C-406406		
50 x 3	50 x 3	WEP 150	BB14-D-503503		HCD 001
50 x 4	50 x 4	WEP 200	BB14-D-504504		
50 x 5	50 x 5		BB14-D-505505		
50 x 6	50 x 6	WEP 250	BB14-D-506506		
50 x 8	50 x 8	2 x WEP 150	BB14-D-508508		

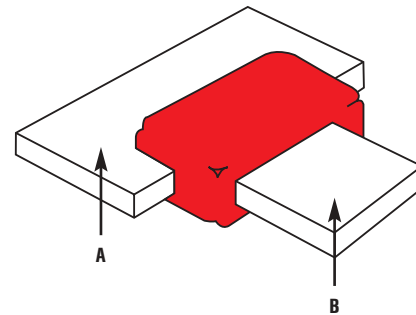

### BB41 - Bar to Bar

A mm x mm	B mm x mm	Weld Powder	Mould	Handle Clamp	
20 x 3	20 x 3	WEP 065	BB41-C-203203	HCC 001	
25 x 3	25 x 3		BB41-C-253253		
25 x 4	25 x 4	WEP 090	BB41-C-254254		
25 x 6	25 x 6	WEP 115	BB41-C-256256		
30 x 2	30 x 2	WEP 090	BB41-C-302302		
30 x 3	30 x 3	WEP 115	BB41-C-303303		
30 x 4	30 x 4		BB41-C-304304		
30 x 5	30 x 5		BB41-C-305305		
31 x 3	31 x 3		BB41-C-313313		
31 x 6	31 x 6		BB41-C-316316		
38 x 3	38 x 3	WEP 150	BB41-C-383383		
38 x 5	38 x 5		BB41-C-385385		
38 x 6	38 x 6	WEP 200	BB41-C-386386		
40 x 3	40 x 3		BB41-C-403403		
40 x 4	40 x 4		BB41-C-404404		
40 x 5	40 x 5		BB41-C-405405		
40 x 6	40 x 6		BB41-C-406406		
50 x 3	50 x 3	WEP 200	BB41-D-503503		HCD 001
50 x 4	50 x 4		BB41-D-504504		
50 x 5	50 x 5		BB41-D-505505		
50 x 6	50 x 6		BB41-D-506506		
50 x 8	50 x 8		WEP 250	BB41-D-508508	

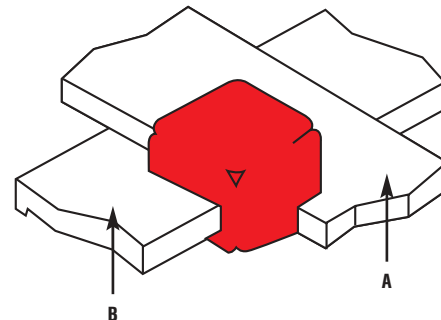

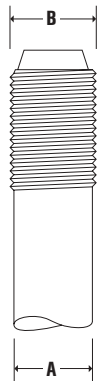
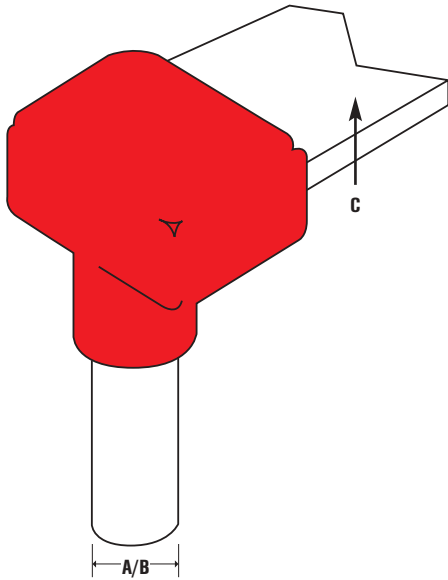

Earth rod threads must be removed before joint is made.

## BR1 - Bar to Earth Rod

A mm	B inches	C mm x mm	Weld Powder	Mould	Handle Clamp
12.7	1/2"	20 x 3	WEP 090	BR1-C-127203	HCC 001
		25 x 3		BR1-C-127253	
		25 x 4		BR1-C-127254	
		30 x 2		BR1-C-127302	
		30 x 3		BR1-C-127303	
		31 x 3		BR1-C-127313	
		38 x 3		BR1-C-127383	
		40 x 3	BR1-C-127403		
		50 x 3	WEP 115	BR1-C-127503	
		50 x 6	BR1-C-127506		
14.2	5/8"	20 x 3	WEP 090	BR1-C-142203	HCC 001
		25 x 3		BR1-C-142253	
		25 x 4	WEP 115	BR1-C-142254	
		25 x 6		BR1-C-142256	
		30 x 2		BR1-C-142302	
		30 x 3		BR1-C-142303	
		30 x 4	WEP 150	BR1-C-142304	
		30 x 5		BR1-C-142305	
		31 x 3	WEP 115	BR1-C-142313	
		31 x 6	WEP 150	BR1-C-142316	
		38 x 3	WEP 115	BR1-C-142383	
		38 x 5	WEP 150	BR1-C-142385	
		38 x 6	WEP 200	BR1-C-142386	
		40 x 3	WEP 115	BR1-C-142403	
		40 x 4	WEP 150	BR1-C-142404	
		40 x 5		BR1-C-142405	
		40 x 6	WEP 200	BR1-C-142406	
		50 x 3	WEP 150	BR1-C-142503	
		50 x 4	WEP 200	BR1-C-142504	
		50 x 5		BR1-C-142505	
50 x 6	BR1-C-142506				
17.2	3/4"	20 x 3	WEP 115	BR1-C-172203	HCC 001
		25 x 3	WEP 150	BR1-C-172253	
		25 x 4		BR1-C-172254	
		25 x 6	WEP 200	BR1-C-172256	
		30 x 2	WEP 150	BR1-C-172302	
		30 x 3		BR1-C-172303	
		30 x 4	WEP 250	BR1-C-172304	
		30 x 5	WEP 200	BR1-C-172305	
		31 x 3	WEP 150	BR1-C-172313	
		31 x 6	WEP 250	BR1-C-172316	
		38 x 3	WEP 200	BR1-C-172383	
		38 x 5		BR1-C-172385	
		38 x 6	2 x WEP 150	BR1-D-172386	HCD 001
		40 x 3	WEP 200	BR1-C-172403	HCC 001
		40 x 4		BR1-C-172404	
		40 x 5		BR1-D-172405	
		40 x 6		BR1-D-172406	HCD 001
		50 x 3		BR1-D-172503	
		50 x 4	2 x WEP 150	BR1-D-172504	
		50 x 5		BR1-D-172505	
50 x 6	2 x WEP 200	BR1-D-172506			
50 x 8		BR1-D-172508			

Suitable only for Copperbond Earth Rods. Please contact our sales office for details on connections to Solid Copper and Stainless Steel Earth Rods.

## CU-NNECT EXOTHERMIC WELDING

### BR2 - Bar to Earth Rod

A mm	B inches	C mm x mm	Weld Powder	Mould	Handle Clamp	
12.7	1/2"	20 x 3	WEP 090	BR2-C-127203	HCC 001	
		25 x 3		BR2-C-127253		
		25 x 4		BR2-C-127254		
		30 x 2		BR2-C-127302		
		30 x 3		BR2-C-127303		
		31 x 3		BR2-C-127313		
		38 x 3		BR2-C-127383		
		40 x 3		BR2-C-127403		
		50 x 3	WEP 115	BR2-C-127503		
		50 x 6		BR2-C-127506		
14.2	5/8"	20 x 3	WEP 090	BR2-C-142203	HCC 001	
		25 x 3		BR2-C-142253		
		25 x 4	WEP 115	BR2-C-142254		
		25 x 6	WEP 150	BR2-C-142256		
		30 x 2	WEP 090	BR2-C-142302		
		30 x 3	WEP 115	BR2-C-142303		
		30 x 4	WEP 150	BR2-C-142304		
		30 x 5		BR2-C-142305		
		31 x 3	WEP 115	BR2-C-142313		
		31 x 6	WEP 150	BR2-C-142316		
		38 x 3		BR2-C-142383		
		38 x 5		BR2-C-142385		
		38 x 6	WEP 200	BR2-C-142386		
		40 x 3	WEP 150	BR2-C-142403		
		40 x 4		BR2-C-142404		
		40 x 5		BR2-C-142405		
		40 x 6	WEP 200	BR2-C-142406		
		50 x 3		BR2-C-142503		
		50 x 4		BR2-C-142504		
		50 x 5	WEP 250	BR2-C-142505		
50 x 6	BR2-C-142506					
17.2	3/4"	20 x 3	WEP 150	BR2-C-172203	HCC 001	
		25 x 3		BR2-C-172253		
		25 x 4	WEP 200	BR2-C-172254		
		25 x 6		BR2-C-172256		
		30 x 2	WEP 150	BR2-C-172302		
		30 x 3		BR2-C-172303		
		30 x 4	WEP 250	BR2-C-172304		
		30 x 5	WEP 200	BR2-C-172305		
		31 x 3		BR2-C-172313		
		31 x 6	WEP 250	BR2-C-172316		
		38 x 3	WEP 200	BR2-C-172383		
		38 x 5		BR2-C-172385		
		38 x 6	WEP 250	BR2-C-172386		
		40 x 3	WEP 200	BR2-C-172403		
		40 x 4		BR2-C-172404		
		40 x 5		BR2-C-172405		
		40 x 6	WEP 250	BR2-C-172406		
		50 x 3	2 x WEP 150	BR2-D-172503		HCD 001
		50 x 4		BR2-D-172504		
		50 x 5		BR2-D-172505		
50 x 6	BR2-D-172506					
50 x 8	2 x WEP 200	BR2-D-172508				

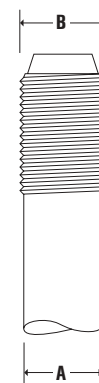
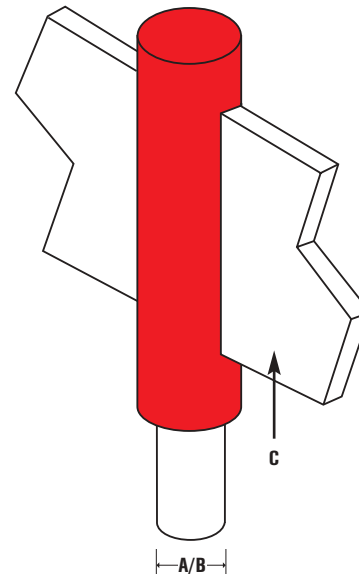

Earth rod threads  
must be removed  
before joint is made.

Suitable only for Copperbond Earth Rods. Please contact our sales office for details on connections to Solid Copper and Stainless Steel Earth Rods.

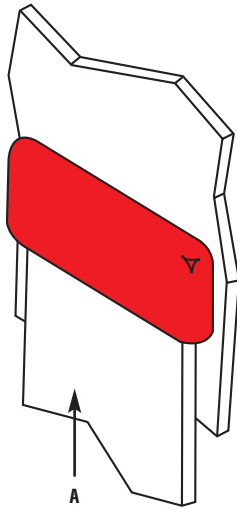

## BS1 - Bar to Steel Surface

A mm x mm	Weld Powder	Mould	Handle Clamp
20 x 3	WEP 065	BS1-C-203	HCC 001
25 x 3	WEP 090	BS1-C-253	
25 x 4		BS1-C-254	
25 x 6	WEP 150	BS1-C-256	
30 x 2	WEP 090	BS1-C-302	
30 x 3		BS1-C-303	
30 x 4	WEP 115	BS1-C-304	
30 x 5	WEP 150	BS1-C-305	
31 x 3	WEP 090	BS1-C-313	
31 x 6	WEP 200	BS1-C-316	
38 x 3	WEP 150	BS1-C-383	
38 x 5	WEP 200	BS1-C-385	
38 x 6	WEP 250	BS1-C-386	
40 x 3	WEP 150	BS1-C-403	
40 x 4	WEP 200	BS1-C-404	
40 x 5		BS1-C-405	
40 x 6	WEP 250	BS1-C-406	
50 x 3	WEP 200	BS1-C-503	
50 x 4	WEP 250	BS1-C-504	
50 x 5		BS1-C-505	
50 x 6	2 x WEP 150	BS1-D-506	HCD 001

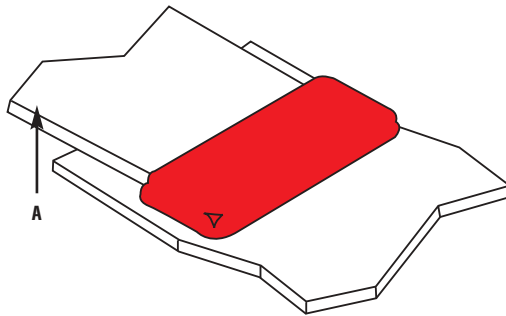

## BS2 - Bar to Steel Surface

A mm x mm	Weld Powder	Mould	Handle Clamp
20 x 3	WEP 090	BS2-C-203	HCC 001
25 x 3		BS2-C-253	
25 x 4		BS2-C-254	
25 x 6	WEP 150	BS2-C-256	
30 x 2	WEP 115	BS2-C-302	
30 x 3		BS2-C-303	
30 x 4	WEP 150	BS2-C-304	
30 x 5	WEP 200	BS2-C-305	
31 x 3	WEP 115	BS2-C-313	
31 x 6	WEP 200	BS2-C-316	
38 x 3	WEP 150	BS2-C-383	
38 x 5	WEP 200	BS2-C-385	
38 x 6		BS2-C-386	
40 x 3	WEP 115	BS2-C-403	
40 x 4	WEP 200	BS2-C-404	
40 x 5		BS2-C-405	
40 x 6	WEP 250	BS2-C-406	
50 x 3	WEP 200	BS2-C-503	
50 x 4	2 x WEP 150	BS2-D-504	HCD 001
50 x 5		BS2-D-505	
50 x 6		BS2-D-506	

## CU-NNECT EXOTHERMIC WELDING

### BS3 - Bar to Steel Surface

A mm x mm	Weld Powder	Mould	Handle Clamp
20 x 3	WEP 090	BS3-C-203	HCC 001
25 x 3	WEP 115	BS3-C-253	
25 x 4		BS3-C-254	
25 x 6	WEP 150	BS3-C-256	
30 x 2	WEP 115	BS3-C-302	
30 x 3		BS3-C-303	
30 x 4	WEP 150	BS3-C-304	
30 x 5	WEP 200	BS3-C-305	
31 x 3	WEP 115	BS3-C-313	
31 x 6	WEP 200	BS3-C-316	
38 x 3	WEP 150	BS3-C-383	
38 x 5	WEP 200	BS3-C-385	
38 x 6	WEP 250	BS3-C-386	
40 x 3	WEP 150	BS3-C-403	
40 x 4	WEP 200	BS3-C-404	
40 x 5	WEP 250	BS3-C-405	
40 x 6		BS3-C-406	
50 x 3		BS3-C-503	
50 x 4		BS3-C-504	
50 x 5		BS3-C-505	
50 x 6		BS3-C-506	

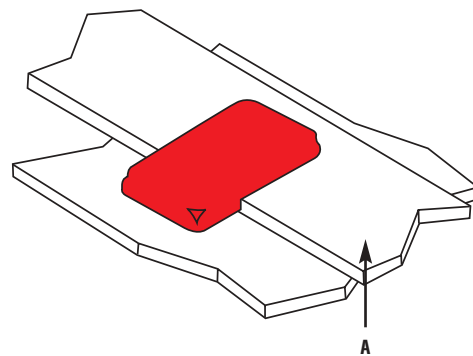

### BS4 - Bar to Steel Surface

A mm x mm	Weld Powder	Mould	Handle Clamp	
20 x 3	WEP 090	BS4-C-203	HCC 001	
25 x 3	WEP 115	BS4-C-253		
25 x 4	WEP 150	BS4-C-254		
25 x 6		BS4-C-256		
30 x 2	WEP 115	BS4-C-302		
30 x 3		BS4-C-303		
30 x 4	WEP 200	BS4-C-304		
30 x 5		BS4-C-305		
31 x 3	WEP 150	BS4-C-313		
31 x 6	WEP 200	BS4-C-316		
38 x 3	WEP 150	BS4-C-383		
38 x 5	WEP 200	BS4-C-385		
38 x 6	WEP 250	BS4-C-386		
40 x 3	WEP 150	BS4-C-403		
40 x 4	WEP 200	BS4-C-404		
40 x 5		BS4-C-405		
40 x 6	WEP 250	BS4-C-406		
50 x 3	WEP 200	BS4-C-503		
50 x 4	WEP 250	BS4-C-504		
50 x 5	2 x WEP 150	BS4-D-505		HCD 001
50 x 6		BS4-D-506		

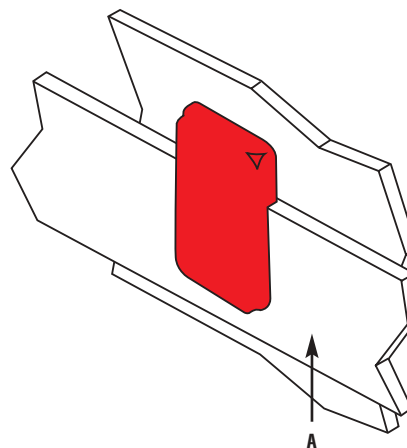

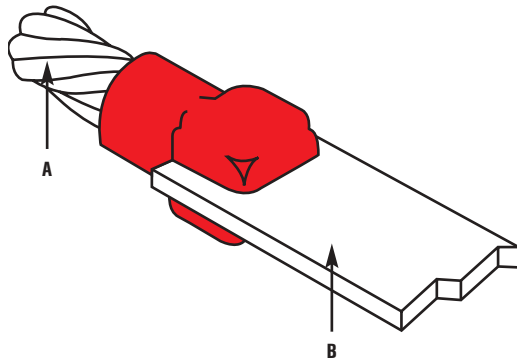

### CB1 - Cable to Bar

A mm <sup>2</sup>	B mm x mm	Weld Powder	Mould	Handle Clamp	
16	20 x 3	WEP 045	CB1-C-16203	HCC 001	
	25 x 3		CB1-C-16253		
25	20 x 3		CB1-C-25203		
	25 x 3		CB1-C-25253		
35	20 x 3		CB1-C-35203		
	25 x 3		CB1-C-35253		
8mm Ø	20 x 3		WEP 065		CB1-C-8SC203
	25 x 3		WEP 045		CB1-C-8SC253
50	20 x 3		WEP 045		CB1-C-50203
	25 x 3		WEP 065		CB1-C-50253
70	25 x 3	CB1-C-70253			
	25 x 4	CB1-C-70254			
95	25 x 6	WEP 090		CB1-C-70256	
	25 x 3		CB1-C-95253		
	25 x 4		CB1-C-95254		
120	25 x 6		CB1-C-95256		
	25 x 3		CB1-C-120253		
	25 x 4		CB1-C-120254		
	25 x 6		CB1-C-120256		
150	30 x 5		WEP 115	CB1-C-120256	
	25 x 6		WEP 115	CB1-C-150256	
	30 x 5		WEP 150	CB1-C-150305	
	40 x 5	WEP 150	CB1-C-150405		
	50 x 3	WEP 115	CB1-C-150503		
	50 x 4	WEP 150	CB1-C-150504		
	50 x 6	WEP 150	CB1-C-150506		
185	50 x 8	WEP 200	CB1-C-150508		
	30 x 5	WEP 150	CB1-C-185305		
	31 x 6		CB1-C-185316		
	38 x 6		CB1-C-185386		
	40 x 5		CB1-C-185405		
	50 x 4	WEP 200	CB1-D-185504		
	50 x 5		CB1-D-185505		
50 x 6	CB1-D-185506				
240	50 x 8	WEP 250	CB1-D-185508		
	50 x 3	WEP 200	CB1-D-240503		
	50 x 4		CB1-D-240504		
	50 x 5		CB1-D-240505		
50 x 6	CB1-D-240506				
300	50 x 6	2 x WEP 150	CB1-D-240506		
	50 x 8	2 x WEP 200	CB1-D-300508		
				HCD 001	



## CU-NNECT EXOTHERMIC WELDING

### CB4 - Cable to Bar

A mm x mm	B mm <sup>2</sup>	Weld Powder	Mould	Handle Clamp
20 x 3	16	WEP 045	CB4-C-20316	HCC 001
	25		CB4-C-20325	
	35		CB4-C-20335	
	8mm Ø		CB4-C-2038SC	
	50		CB4-C-20350	
25 x 3	16	WEP 032	CB4-C-25316	
	25		CB4-C-25325	
	35	WEP 045	CB4-C-25335	
	8mm Ø		CB4-C-2538SC	
	50		CB4-C-25350	
	70	WEP 065	CB4-C-25370	
	95	WEP 090	CB4-C-25395	
120	CB4-C-253120			
25 x 4	70	WEP 065	CB4-C-25470	
	95	WEP 090	CB4-C-25495	
	120		CB4-C-254120	
25 x 6	70	WEP 115	CB4-C-25670	
	95		CB4-C-25695	
	120		CB4-C-256120	
	150		CB4-C-256150	
30 x 5	120	WEP 150	CB4-C-305120	
	150		CB4-C-305150	
	185		CB4-C-305185	
31 x 6	185	WEP 150	CB4-C-316185	
38 x 6	185		CB4-C-386185	
40 x 5	150	WEP 115	CB4-C-405150	
	185	WEP 150	CB4-C-405185	
50 x 3	150	WEP 115	CB4-C-503150	
	240	WEP 200	CB4-C-503240	
50 x 4	150	WEP 115	CB4-C-504150	
	185	WEP 150	CB4-C-504185	
	240	WEP 200	CB4-C-504240	
50 x 5	185	WEP 150	CB4-C-505185	
	240	WEP 200	CB4-C-505240	
50 x 6	150	WEP 150	CB4-C-506150	
	185		CB4-C-506185	
	240	WEP 250	CB4-C-506240	
	300	2 x WEP 150	CB4-D-506300	HCD 001
50 x 8	150	WEP 150	CB4-C-508150	HCC 001
	185	WEP 200	CB4-C-508185	
	300	2 x WEP 200	CB4-D-508300	HCD 001

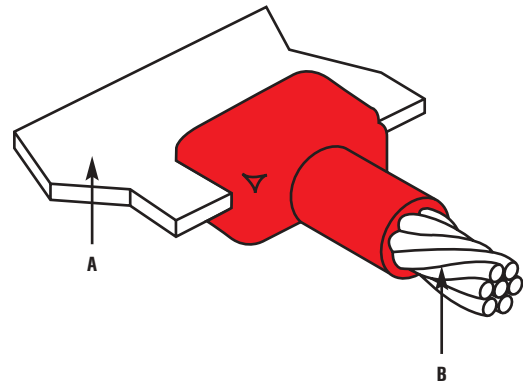

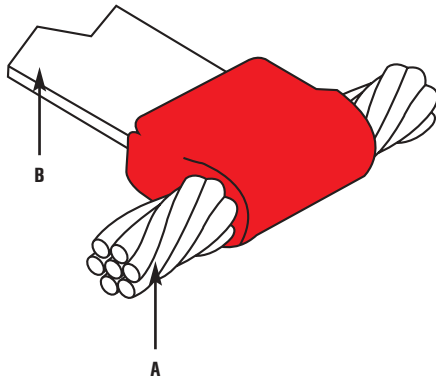

### CB5 - Cable to Bar

A mm <sup>2</sup>	B mm x mm	Weld Powder	Mould	Handle Clamp
16	20 x 3	WEP 045	CB5-C-16203	HCC 001
	25 x 3	WEP 065	CB5-C-16253	
25	20 x 3	WEP 045	CB5-C-25203	
	25 x 3	WEP 065	CB5-C-25253	
35	20 x 3	WEP 045	CB5-C-35203	
	25 x 3	WEP 065	CB5-C-35253	
8mm Ø	20 x 3		CB5-C-8SC203	
	25 x 3		CB5-C-8SC253	
50	20 x 3		WEP 090	
	25 x 3	CB5-C-50253		
70	25 x 3	WEP 090	CB5-C-70253	
	25 x 4	WEP 115	CB5-C-70254	
	25 x 6		CB5-C-70256	
95	25 x 3	WEP 150	CB5-C-95253	
	25 x 4		CB5-C-95254	
	25 x 6		CB5-C-95256	
120	25 x 3	WEP 200	CB5-C-120253	
	25 x 4		CB5-C-120254	
	25 x 6		CB5-C-120256	
	30 x 5		CB5-C-120305	
150	25 x 6	WEP 250	CB5-C-150256	
	30 x 5		CB5-C-150305	
	40 x 5	WEP 250	CB5-C-150405	
	50 x 3	WEP 200	CB5-C-150503	
	50 x 4	WEP 250	CB5-C-150503	
	50 x 6	2 x WEP 150	CB5-D-150506	
185	50 x 8	2 x WEP 200	CB5-D-150508	
	30 x 5	WEP 250	CB5-C-185305	
	31 x 6		CB5-C-185316	
	38 x 6		CB5-C-185386	
	40 x 5		CB5-C-185405	
	50 x 4	2 x WEP 150	CB5-D-185504	
	50 x 5		CB5-D-185505	
50 x 6	CB5-D-185506			
240	50 x 8	2 x WEP 200	CB5-D-185508	
	50 x 3	2 x WEP 150	CB5-D-185503	
	50 x 4		CB5-D-240504	
	50 x 5		CB5-D-240505	
50 x 6	CB5-D-240506			
300	50 x 6	2 x WEP 250	CB5-D-240506	
	50 x 8		CB5-D-300508	

## CU-NNECT EXOTHERMIC WELDING

### CC1 - Cable to Cable

A mm <sup>2</sup>	Weld Powder	Mould	Handle Clamp
16	WEP 032	CC1-C-16	HCC 001
25		CC1-C-25	
35		CC1-C-35	
8mm Ø	WEP 045	CC1-C-8SC	
50		CC1-C-50	
70	WEP 065	CC1-C-70	
95	WEP 090	CC1-C-95	
120	WEP 115	CC1-C-120	
150		CC1-C-150	
185	WEP 150	CC1-C-185	
240	WEP 200	CC1-C-240	
300	WEP 250	CC1-C-300	
400	2 x WEP 150	CC1-D-400	

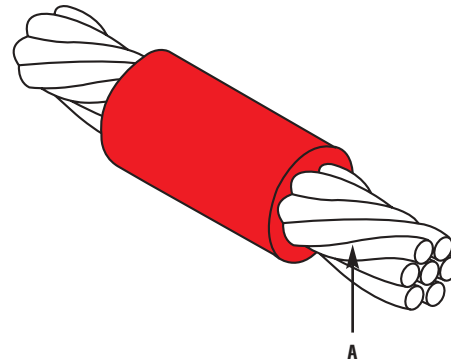

### CC2 - Cable to Cable

A mm <sup>2</sup>	B mm <sup>2</sup>	Weld Powder	Mould	Handle Clamp
16	16	WEP 045	CC2-C-1616	HCC 001
25	25		CC2-C-2525	
35	25		CC2-C-3525	
	35		CC2-C-3535	
8mm Ø	8mm Ø	WEP 065	CC2-C-88SC	
50	25		CC2-C-5025	
	35		CC2-C-5035	
70	50	WEP 090	CC2-C-5050	
	25	WEP 065	CC2-C-7025	
	35		CC2-C-7035	
	50		CC2-C-7050	
95	70	WEP 090	CC2-C-7070	
	35		CC2-C-9535	
	50		CC2-C-9550	
	70		CC2-C-9570	
120	95	WEP 115	CC2-C-9595	
	35	WEP 090	CC2-C-12035	
	50		CC2-C-12050	
	70		CC2-C-12070	
150	95	WEP 150	CC2-C-12095	
	120		CC2-C-120120	
	50	WEP 090	CC2-C-15050	
	70		CC2-C-15070	
	95		CC2-C-15095	
185	120	WEP 200	CC2-C-150120	
	150		CC2-C-150150	
	70		CC2-C-18570	
	95		CC2-C-18595	
240	120	WEP 200	CC2-C-185120	
	150		CC2-C-185150	
	185		CC2-C-185185	
240	95	WEP 150	CC2-C-24095	HCC 001
	120	WEP 200	CC2-C-240120	

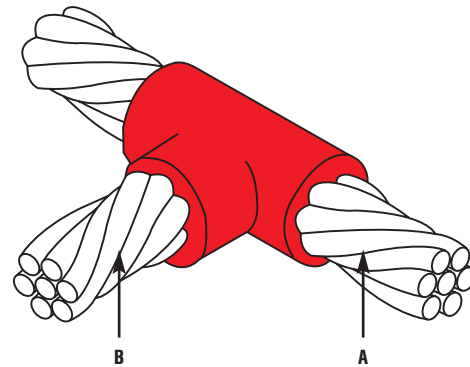
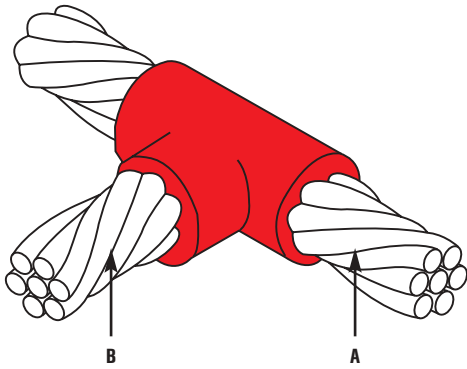
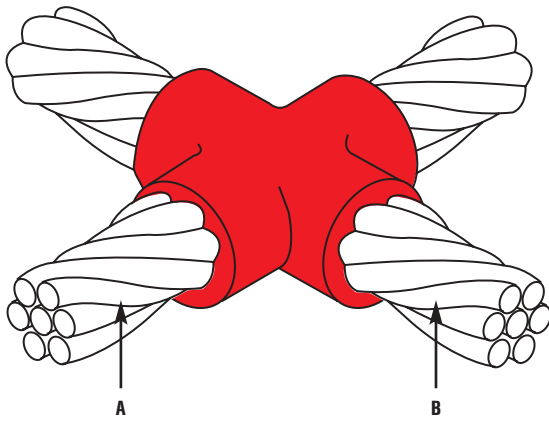

Table continued on page 18



## CC2 - Cable to Cable (continued)

A mm <sup>2</sup>	B mm <sup>2</sup>	Weld Powder	Mould	Handle Clamp
240	150	WEP 200	CC2-C-240150	HCC 001
	185		CC2-C-240185	
	240	2 x WEP 150	CC2-D-240240	HCD 001
300	120	WEP 150	CC2-C-300120	HCC 001
	150	WEP 200	CC2-C-300150	
	185	WEP 250	CC2-C-300185	
	240	2 x WEP 200	CC2-D-300240	HCD 001
	300		CC2-D-300300	



## CC4 - Cable to Cable

A mm <sup>2</sup>	B mm <sup>2</sup>	Weld Powder	Mould	Handle Clamp
16	16	WEP 045	CC4-C-1616	HCC 001
25	25		CC4-C-2525	
35	25	WEP 065	CC4-C-3525	
	35		CC4-C-3535	
8mm Ø	8mm Ø	WEP 090	CC4-C-88SC	
50	25		CC4-C-5025	
	35		CC4-C-5035	
	50	CC4-C-5050		
70	25	WEP 115	CC4-C-7025	
	35		CC4-C-7035	
	50		CC4-C-7050	
	70		CC4-C-7070	
95	35	WEP 150	CC4-C-9535	
	50		CC4-C-9550	
	70		CC4-C-9570	
120	95	WEP 115	CC4-C-9595	
	35		CC4-C-12035	
	50		CC4-C-12050	
	70		CC4-C-12070	
150	95	WEP 150	CC4-C-12095	
	120		CC4-C-120120	
	50	WEP 200	CC4-C-15050	
	70		CC4-C-15070	
185	95	WEP 150	CC4-C-15095	
	120		CC4-C-150120	
	150	WEP 250	CC4-C-150150	
	185		CC4-C-150185	
240	70	WEP 200	CC4-C-18570	
	95		CC4-C-18595	
	120	WEP 250	CC4-C-185120	
	150		CC4-C-185150	
300	185	2 x WEP 150	CC4-D-185185	
	240		CC4-D-24095	
	120	2 x WEP 200	CC4-D-240120	
	150		CC4-D-240150	
300	185	2 x WEP 250	CC4-D-240185	
	240		CC4-D-240240	
	120	3 x WEP 200	CC4-D-300120	
	150		CC4-D-300150	
	185		CC4-D-300185	
300	240	3 x WEP 200	CC4-D-300240	
	300		CC4-D-300300	

## CU-NNECT EXOTHERMIC WELDING

### CC7 - Cable to Cable

A mm <sup>2</sup>	B mm <sup>2</sup>	Weld Powder	Mould	Handle Clamp
16	16	WEP 045	CC7-C-1616	HCC 001
25	25		CC7-C-2525	
35	25	WEP 065	CC7-C-3525	
	35		CC7-C-3535	
8mm Ø	8mm Ø	WEP 090	CC7-C-88SC	
50	25	WEP 065	CC7-C-5025	
	35	WEP 090	CC7-C-5035	
	50		CC7-C-5050	
70	25	WEP 090	CC7-C-7025	
	35		CC7-C-7035	
	50	WEP 115	CC7-C-7050	
70	CC7-C-7070			
95	35	WEP 115	CC7-C-9535	
	50		CC7-C-9550	
	70	WEP 150	CC7-C-9570	
	95		CC7-C-9595	
120	35	WEP 150	CC7-C-12035	
	50		CC7-C-12050	
	70	WEP 200	CC7-C-12070	
	95		CC7-C-12095	
150	120	WEP 150	CC7-C-120120	
	50		CC7-C-15050	
	70	WEP 200	CC7-C-15070	
	95		CC7-C-15095	
	120	WEP 250	CC7-C-150120	
150	2 x WEP 150	CC7-D-150150	HCD 001	
185	70	WEP 200	CC7-C-18570	
	95		CC7-C-18595	
	120	WEP 250	CC7-C-185120	
	150		2 x WEP 150	CC7-D-185150
185	2 x WEP 150	CC7-D-185185	HCD 001	
240	95	WEP 250	CC7-C-24095	
	120		CC7-C-240120	
	150	2 x WEP 150	CC7-D-240150	
	185		CC7-D-240185	
240	2 x WEP 200	CC7-D-240240	HCD 001	
300	120	2 x WEP 150	CC7-D-300120	
	150		CC7-D-300300	
	185	2 x WEP 200	CC7-D-300185	
	240		CC7-D-300240	
	300	2 x WEP 250	CC7-D-300300	

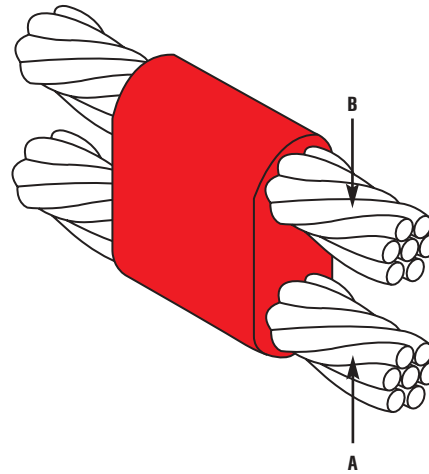

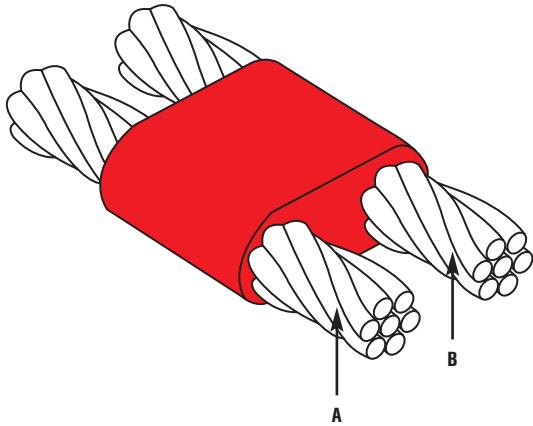

### CC14 - Cable to Cable

A mm <sup>2</sup>	B mm <sup>2</sup>	Weld Powder	Mould	Handle Clamp
16	16	WEP 045	CC14-C-1616	HCC 001
25	25		CC14-C-2525	
35	25	WEP 065	CC14-C-3525	
	35		CC14-C-3535	
8mm Ø	8mm Ø	WEP 090	CC14-C-88SC	
50	25		CC14-C-5025	
	35		CC14-C-5035	
	50		CC14-C-5050	
70	25	WEP 115	CC14-C-7025	
	35		CC14-C-7035	
	50		CC14-C-7050	
95	70	WEP 150	CC14-C-7070	
	35		CC14-C-9535	
	50		CC14-C-9550	
120	70	WEP 200	CC14-C-9570	
	95		CC14-C-9595	
	35		CC14-C-12035	
	50		CC14-C-12050	
150	70	WEP 250	CC14-C-12070	
	95		CC14-C-12095	
	120	CC14-C-120120		
	150	CC14-C-15050		
185	70	WEP 150	CC14-C-15070	
	95		CC14-C-15095	
	120	WEP 200	CC14-C-150120	
	150	2 x WEP 150	CC14-D-150150	HCD 001
240	70	WEP 200	CC14-C-18570	
	95		CC14-C-18595	
	120	WEP 250	CC14-C-185120	
	150	2 x WEP 150	CC14-D-185150	HCD 001
300	185	2 x WEP 150	CC14-D-185185	HCD 001
	95	WEP 250	CC14-C-24095	
	120		CC14-C-240120	
	150	2 x WEP 150	CC14-D-240150	HCD 001
185	2 x WEP 150	CC14-D-240185		
240	2 x WEP 200	CC14-D-240240		
120	2 x WEP 150	CC14-D-300120		
300	150	2 x WEP 150	CC14-D-300150	
	185	2 x WEP 200	CC14-D-300185	
	240	2 x WEP 200	CC14-C-300240	
	300	2 x WEP 250	CC14-D-300300	

## CU-NNECT EXOTHERMIC WELDING

### CR1 - Cable to Earth Rod

A mm	B inches	C mm <sup>2</sup>	Weld Powder	Mould	Handle Clamp
12.7	1/2"	16	WEP 065	CR1-C-12716	HCC 001
		25		CR1-C-12725	
		35		CR1-C-12735	
		8mm Ø		CR1-C-1278SC	
		50	WEP 090	CR1-C-12750	
		70		CR1-C-12770	
		95		CR1-C-12795	
		120		CR1-C-127120	
		150	WEP 115	CR1-C-127150	
		185		CR1-C-127185	
		240	WEP 150	CR1-C-127240	
		300		CR1-C-127300	
14.2	5/8"	16	WEP 065	CR1-C-14216	HCC 001
		25		CR1-C-14225	
		35		CR1-C-14235	
		8mm Ø		CR1-C-1428SC	
		50	WEP 090	CR1-C-14250	
		70		CR1-C-14270	
		95		CR1-C-14295	
		120		CR1-C-142120	
		150	WEP 115	CR1-C-142150	
		185		CR1-C-142185	
		240	WEP 150	CR1-C-142240	
		300	WEP 200	CR1-C-142300	
17.2	3/4"	16	WEP 065	CR1-C-17216	HCC 001
		25		CR1-C-17225	
		35		CR1-C-17235	
		8mm Ø		CR1-C-1728SC	
		50	WEP 090	CR1-C-17250	
		70		CR1-C-17270	
		95		CR1-C-17295	
		120		CR1-C-172120	
		150	WEP 115	CR1-C-172150	
		185		CR1-C-172185	
		240	WEP 150	CR1-C-172240	
		300	WEP 200	CR1-C-172300	

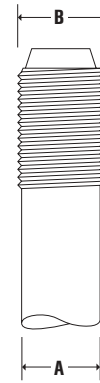
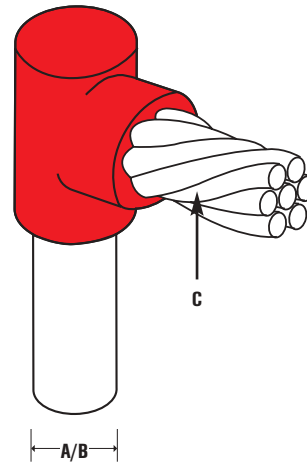

Earth rod threads  
must be removed  
before joint is made.

Suitable only for Copperbond Earth Rods. Please contact our sales office for details on connections to Solid Copper and Stainless Steel Earth Rods.

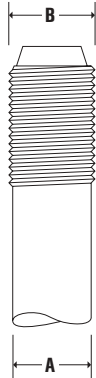
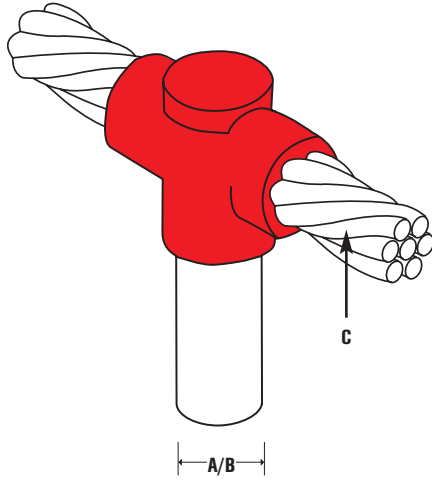

Earth rod threads must be removed before joint is made.

## CR2 - Cable to Earth Rod

A mm	B inches	C mm <sup>2</sup>	Weld Powder	Mould	Handle Clamp
12.7	1/2"	16	WEP 090	CR2-C-12716	HCC 001
		25		CR2-C-12725	
		35		CR2-C-12735	
		8mm Ø	WEP 065	CR2-C-1278SC	
		50	WEP 090	CR2-C-12750	
		70		CR2-C-12770	
		95	WEP 115	CR2-C-12795	
		120	WEP 150	CR2-C-127120	
		150		CR2-C-127150	
		185	WEP 200	CR2-C-127185	
		240		CR2-C-127240	
		300	WEP 250	CR2-C-127300	
14.2	5/8"	16	WEP 065	CR2-C-14216	HCC 001
		25	WEP 090	CR2-C-14225	
		35		CR2-C-14235	
		8mm Ø		CR2-C-1428SC	
		50	WEP 115	CR2-C-14250	
		70		CR2-C-14270	
		95	WEP 150	CR2-C-14295	
		120	WEP 200	CR2-C-142120	
		150		CR2-C-142150	
		185	WEP 250	CR2-C-142185	
		240	WEP 250	CR2-C-142240	
		300	2 x WEP 150	CR2-D-142300	
17.2	3/4"	16	WEP 090	CR2-C-17216	HCC 001
		25		CR2-C-17225	
		35		CR2-C-17235	
		8mm Ø	WEP 115	CR2-C-1728SC	
		50		CR2-C-17250	
		70	CR2-C-17270		
		95	WEP 150	CR2-C-17295	
		120	WEP 200	CR2-C-172120	
		150		CR2-C-172150	
		185	WEP 250	CR2-C-172185	
		240	WEP 250	CR2-C-172240	
		300	2 x WEP 150	CR2-D-172300	

Suitable only for Copperbond Earth Rods. Please contact our sales office for details on connections to Solid Copper and Stainless Steel Earth Rods.



## CU-NNECT EXOTHERMIC WELDING

### CR3 - Cable to Earth Rod

A mm	B inches	C mm <sup>2</sup>	Weld Powder	Mould	Handle Clamp	
12.7	1/2"	16	WEP 090	CR3-E-12716	HCC 001	
		25		CR3-E-12725		
		35		CR3-E-12735		
		8mm Ø	WEP 115	CR3-E-1278SC		
		50		CR3-E-12750		
		70		CR3-E-12770		
		95		CR3-E-12795		
		120	WEP 150	CR3-E-127120		
		150		CR3-E-127150		
		185	WEP 250	CR3-E-127185		
		240	2 x WEP 200	CR3-E-127240		
		300	2 x WEP 250	CR3-E-127300		
14.2	5/8"	16	WEP 090	CR3-E-14216	HCC 001	
		25		CR3-E-14225		
		35		CR3-E-14235		
		8mm Ø	WEP 115	CR3-E-1428SC		
		50		CR3-E-14250		
		70		CR3-E-14270		
		95		CR3-E-14295		
		120	WEP 150	CR3-E-142120		
		150	WEP 200	CR3-E-142150		
		185	WEP 250	CR3-E-142185		
		240	2 x WEP 200	CR3-J-142240		HCD 001
		300	2 x WEP 250	CR3-J-142300		
17.2	3/4"	16	WEP 090	CR3-E-17216	HCC 001	
		25		CR3-E-17225		
		35		CR3-E-17235		
		8mm Ø	WEP 115	CR3-E-1728SC		
		50		CR3-E-17250		
		70		CR3-E-17270		
		95		CR3-E-17295		
		120	WEP 200	CR3-E-172120		
		150	WEP 250	CR3-E-172150		
		185	2 x WEP 200	CR3-J-172185		HCD 001
		240		CR3-J-172240		
		300	3 x WEP 200	CR3-J-172300		

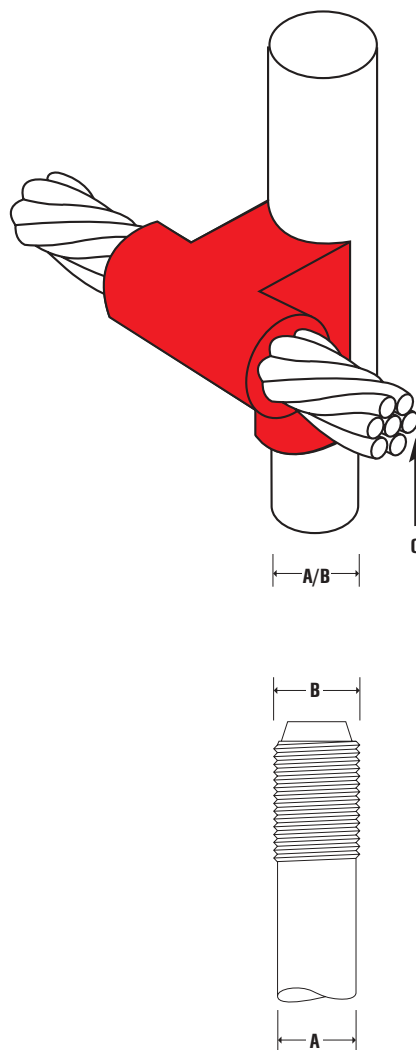

Earth rod threads  
must be removed  
before joint is made.

Suitable only for Copperbond Earth Rods. Please contact our sales office for details on connections to Solid Copper and Stainless Steel Earth Rods.

### CRE1 - Cable to Rebar

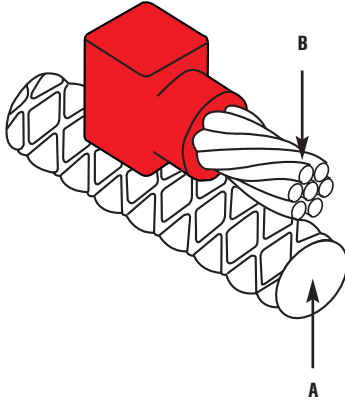

A mm	B mm <sup>2</sup>	Weld Powder	Mould	Handle Clamp
10 - 40	16	WEP 045	CRE1-A-16	HCA 001
	25		CRE1-A-25	
	35		CRE1-A-35	
	8mm Ø	WEP 090	CRE1-C-8SC	HCC 004
	50		CRE1-C-50	
	70		CRE1-C-70	
	95		CRE1-C-95	
	120		CRE1-C-120	
	150	WEP 150	CRE1-C-150	HCD 004
	185	WEP 250	CRE1-C-185	
	240	2 x WEP 150	CRE1-D-240	
	300		CRE1-D-300	

To safely and effectively weld cable to rebar some form of mould packing must be used. Preformed ceramic fibre packing (part no. PAK001) or Duxseal (Part no. DXS001) can be used for this purpose.

### CRE2 - Cable to Rebar

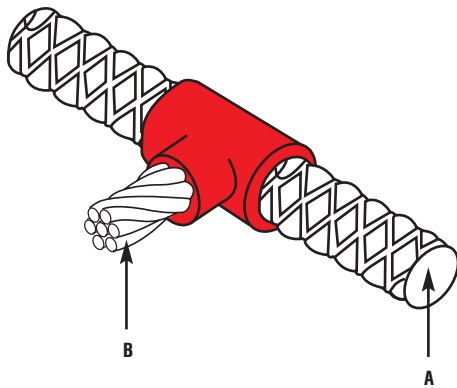

A mm	B mm <sup>2</sup>	Weld Powder	Mould	Handle Clamp	
16	16	WEP 090	CRE2-C-16R16	HCC 001	
	25		CRE2-C-16R25		
	35		CRE2-C-16R35		
	50	WEP 115	CRE2-C-16R50	HCC 001	
	8mm Ø		CRE2-C-16R8SC		
	70	WEP 115	CRE2-C-16R70		
	95	WEP 150	CRE2-C-16R95		
	120		CRE2-C-16R120		
	150	WEP 200	CRE2-C-16R150		
	185		CRE2-C-16R185		
	240	WEP 250	CRE2-C-16R240		
	300	2 x WEP 150	CRE2-D-16R300		HCD 001
20	16	WEP 115	CRE2-C-20R16		HCC 001
	25		CRE2-C-20R25		
	35		CRE2-C-20R35		
	50	WEP 150	CRE2-C-20R50	HCC 001	
	8mm Ø		CRE2-C-20R8SC		
	70	WEP 150	CRE2-C-20R70		
	95	WEP 200	CRE2-C-20R95		
	120		CRE2-C-20R120		
	150	WEP 200	CRE2-C-20R150		
	185	WEP 250	CRE2-C-20R185		
	240	2 x WEP 150	CRE2-D-20R240		HCD 001
	300	2 x WEP 200	CRE2-D-20R300		

Table continued on page 25

To safely and effectively weld cable to rebar some form of mould packing must be used. Preformed ceramic fibre packing (part no. PAK001) or Duxseal (Part no. DXS001) can be used for this purpose.

## CU-NNECT EXOTHERMIC WELDING

### CRE2 - Cable to Rebar (continued)

A mm	B mm <sup>2</sup>	Weld Powder	Mould	Handle Clamp
25	16	WEP 200	CRE2-C-25R16	HCC 001
	25		CRE2-C-25R25	
	35		CRE2-C-25R35	
	50		CRE2-C-25R50	
	8mm Ø		CRE2-C-25R8SC	
	70	WEP 250	CRE2-C-25R70	HCC 001
	95		CRE2-C-25R95	
	120		CRE2-C-25R120	
	150	2 x WEP 150	CRE2-D-25R150	HCD 001
	185		CRE2-D-25R185	
	240	2 x WEP 200	CRE2-D-25R240	
	300		CRE2-D-25R300	
30	16	WEP 250	CRE2-C-30R16	HCC 001
	25		CRE2-C-30R25	
	35		CRE2-C-30R35	
	50	2 x WEP 150	CRE2-D-30R50	HCD 001
	8mm Ø		CRE2-D-30R8SC	
	70		CRE2-D-30R70	
	95	CRE2-D-30R95		
	120	2 x WEP 200	CRE2-D-30R120	
	150		CRE2-D-30R150	
	185	2 x WEP 250	CRE2-D-30R185	
	240		CRE2-D-30R240	
	300	3 x WEP 200	CRE2-D-30R300	

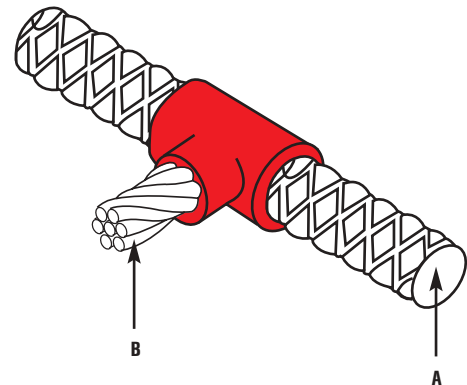

To safely and effectively weld cable to rebar some form of mould packing must be used. Preformed ceramic fibre packing (part no. PAK001) or Duxseal (Part no. DXS001) can be used for this purpose.

### CRE3 - Cable to Rebar

A mm	B mm <sup>2</sup>	Weld Powder	Mould	Handle Clamp
10 - 40	16	WEP 045	CRE3-C-16	HCC 002
	25		CRE3-C-25	
	35		CRE3-C-35	
	8mm Ø		CRE3-C-8SC	
	50	WEP 090	CRE3-C-50	HCC 002
	70		CRE3-C-70	
	95		CRE3-C-95	
	120		CRE3-C-120	
	150		WEP 150	
	185	WEP 250	CRE3-C-185	HCD 002
	240	2 x WEP 150	CRE3-D-240	
	300		CRE3-D-300	

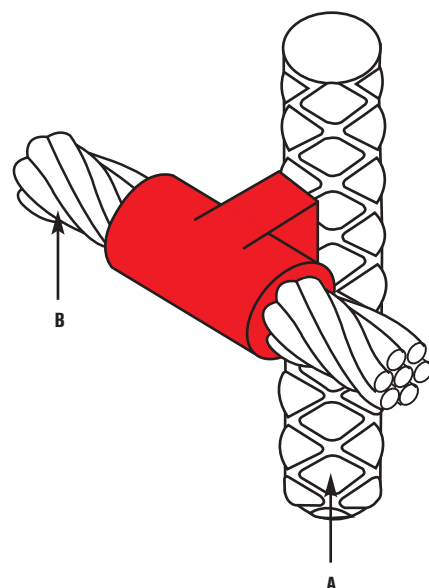

To safely and effectively weld cable to rebar some form of mould packing must be used. Preformed ceramic fibre packing (part no. PAK001) or Duxseal (Part no. DXS001) can be used for this purpose.

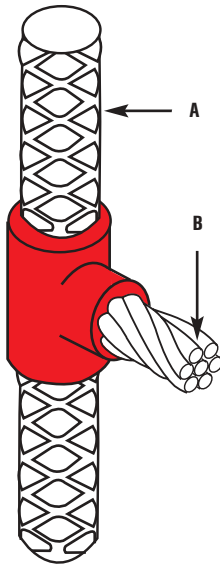

## CRE6 - Cable to Rebar

A mm	B mm <sup>2</sup>	Weld Powder	Mould	Handle Clamp
10 - 40	16	WEP 045	CRE6-C-16	HCC 002
	25		CRE6-C-25	
	35		CRE6-C-35	
	8mm Ø	WEP 065	CRE6-C-8SC	
	50		CRE6-C-50	
	70	WEP 090	CRE6-C-70	
	95		CRE6-C-95	
	120		CRE6-C-120	
	150	WEP 150	CRE6-C-150	
	185		CRE6-C-185	
	240	WEP 200	CRE6-C-240	
	300		CRE6-C-300	

To safely and effectively weld cable to rebar some form of mould packing must be used. Preformed ceramic fibre packing (part no. PAK001) or Duxseal (Part no. DXS001) can be used for this purpose.

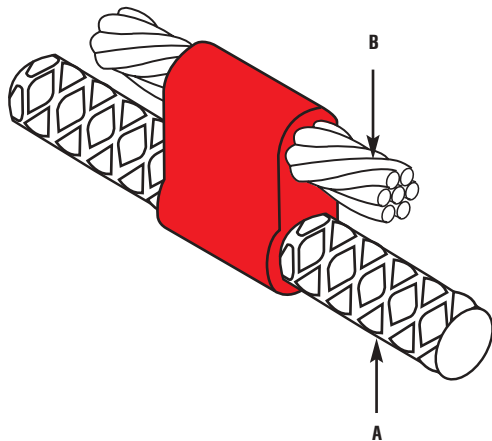

## CRE17 - Cable to Rebar

A mm	B mm <sup>2</sup>	Weld Powder	Mould	Handle Clamp
10 - 40	16	WEP 045	CRE17-C-16	HCC 004
	25		CRE17-C-25	
	35		CRE17-C-35	
	8mm Ø	WEP 090	CRE17-C-8SC	
	50		CRE17-C-50	
	70		CRE17-C-70	
	95		CRE17-C-95	
	120	WEP 150	CRE17-C-120	
	150		CRE17-C-150	
	185		CRE17-C-185	
	240	2 X WEP 150	CRE17-D-240	HCD 004
	300		CRE17-D-300	

To safely and effectively weld cable to rebar some form of mould packing must be used. Preformed ceramic fibre packing (part no. PAK001) or Duxseal (Part no. DXS001) can be used for this purpose.

## CU-NNECT EXOTHERMIC WELDING

### CS1 - Cable to Steel Surface

A mm <sup>2</sup>	Weld Powder	Mould	Handle Clamp
16	USE MOULD TYPE CS8 ON PAGE 28		
25			
35			
8mm Ø	WEP 045	CS1-C-8SC	HCC 001
50		CS1-C-50	
70	WEP 065	CS1-C-70	
95	WEP 090	CS1-C-95	
120	WEP 115	CS1-C-120	
150	WEP 150	CS1-C-150	
185	WEP 200	CS1-C-185	
240		CS1-C-240	
300		CS1-D-300	HCD 001

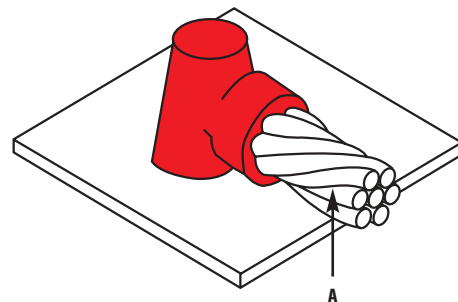

### CS2 - Cable to Steel Surface

A mm <sup>2</sup>	Weld Powder	Mould	Handle Clamp
16	USE MOULD TYPE CS9 ON PAGE 28		
25			
35			
8mm Ø	WEP 090	CS2-C-8SC	HCC 001
50		CS2-C-50	
70	WEP 115	CS2-C-70	
95		CS2-C-95	
120	WEP 150	CS2-C-120	
150	WEP 200	CS2-C-150	
185	WEP 250	CS2-C-185	
240	2 x WEP 150	CS2-D-240	HCD 001
300	2 x WEP 200	CS2-D-300	HCD 001

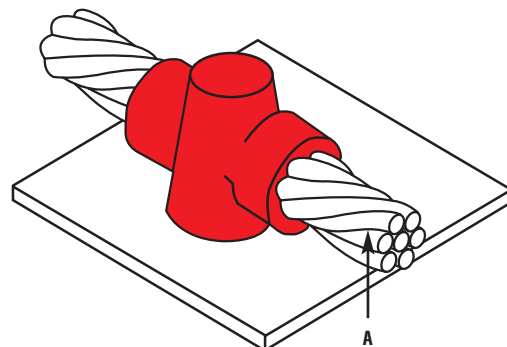

### CS3 - Cable to Steel Surface

A mm <sup>2</sup>	Weld Powder	Mould	Handle Clamp
16	WEP 045	CS3-C-16	HCC 001
25		CS3-C-25	
35		CS3-C-35	
8mm Ø	WEP 065	CS3-C-8SC	
50		CS3-C-50	
70	WEP 090	CS3-C-70	
95	WEP 115	CS3-C-95	
120		CS3-C-120	
150		CS3-C-150	
185	WEP 200	CS3-C-185	
240		CS3-C-240	
300	WEP 250	CS3-C-300	

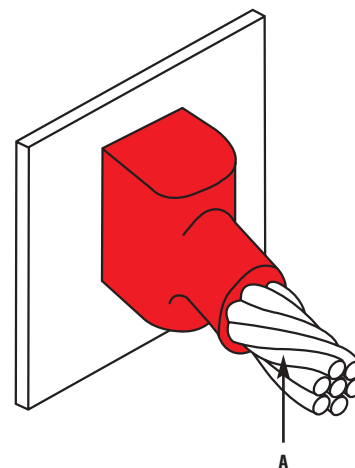

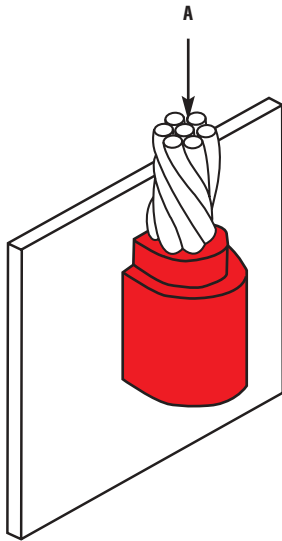

## CS7 - Cable to Steel Surface

A mm <sup>2</sup>	Weld Powder	Mould	Handle Clamp
16	WEP 045	CS7-C-16	HCC 001
25	WEP 065	CS7-C-25	
35		CS7-C-35	
8mm Ø	WEP 090	CS7-C-8SC	
50	WEP 150	CS7-C-50	HCD 001
70		CS7-C-70	
95	WEP 200	CS7-D-95	
120		CS7-D-120	
150	WEP 250	CS7-D-150	
185	2 x WEP 150	CS7-D-185	
240		CS7-D-240	
300	2 x WEP 200	CS7-D-300	

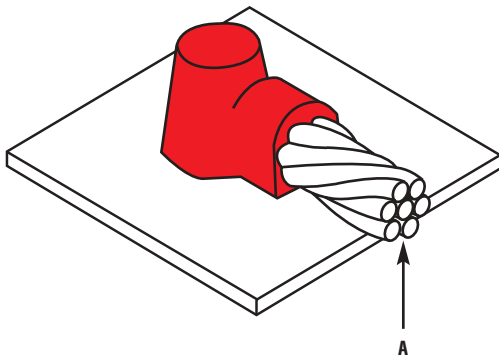

## CS8 - Cable to Steel Surface

A mm <sup>2</sup>	Weld Powder	Mould	Handle Clamp
16	WEP 025	CS8-A-16	HCA 001
25	WEP 032	CS8-A-25	
35		CS8-A-35	
8mm Ø	WEP 045	CS8-A-8SC	HCC 001
50		CS8-A-50	
70	WEP 065	CS8-C-70	
95	WEP 090	CS8-C-95	
120	WEP 115	CS8-C-120	
150	WEP 150	CS8-C-150	
185	WEP 200	CS8-C-185	
240		CS8-C-240	
300	WEP 250	CS8-C-300	

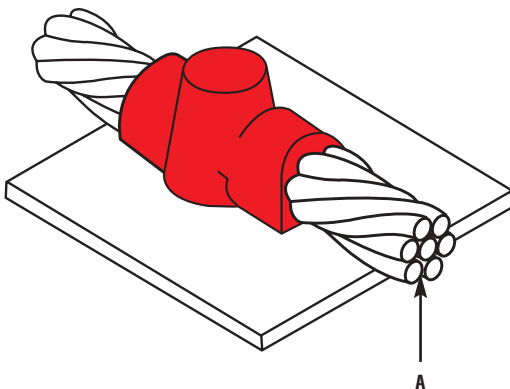

## CS9 - Cable to Steel Surface

A mm <sup>2</sup>	Weld Powder	Mould	Handle Clamp
16	WEP 045	CS9-A-16	HCA 001
25		CS9-A-25	
35		CS9-A-35	
8mm Ø	WEP 090	CS9-C-8SC	HCC 001
50		CS9-C-50	
70	WEP 115	CS9-C-70	
95		CS9-C-95	
120	WEP 150	CS9-C-120	
150	WEP 200	CS9-C-150	
185	WEP 250	CS9-C-185	
240	2 x WEP 150	CS9-C-240	
300	2 x WEP 200	CS9-C-300	

## CU-NNECT EXOTHERMIC WELDING

### CS25 - Cable to Steel Surface

A mm <sup>2</sup>	Weld Powder	Mould	Handle Clamp
16	WEP 045	CS25-C-10	HCC 001
25		CS25-C-25	
35		CS25-C-35	
8mm Ø	WEP 065	CS25-C-8SC	
50		CS25-C-50	
70	WEP 090	CS25-C-70	
95	WEP 115	CS25-C-95	
120		CS25-C-120	
150	WEP 150	CS25-C-150	
185	WEP 200	CS25-C-185	
240		CS25-C-240	
300	WEP 250	CS25-C-300	

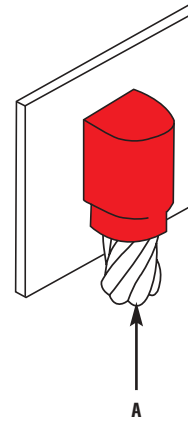

### CS27 - Cable to Steel Surface

A mm <sup>2</sup>	Weld Powder	Mould	Handle Clamp
16	WEP 045	CS27-C-16	HCC 001
25		CS27-C-25	
35		CS27-C-35	
8mm Ø	WEP 065	CS27-C-8SC	
50		CS27-C-50	
70	WEP 115	CS27-C-70	
95	WEP 150	CS27-C-95	
120		CS27-C-120	
150	WEP 200	CS27-C-150	
185	WEP 250	CS27-C-185	HCC 001
240	2 x WEP 150	CS27-D-240	
300	2 x WEP 200	CS27-D-300	

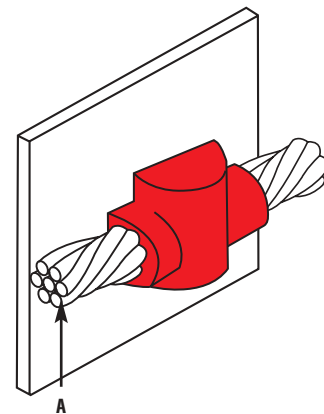

### RS1 - Stud to Steel Surface

A	Weld Powder	Mould	Handle Clamp
M6	WEP 025	RS1-C-M6	HCC 001
M8	WEP 032	RS1-C-M8	
M10	WEP 045	RS1-C-M10	
M12	WEP 065	RS1-C-M12	
M16	WEP 115	RS1-C-M16	

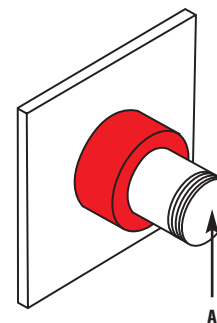

### RS2 - Stud to Steel Surface

A	Weld Powder	Mould	Handle Clamp
M6	WEP 025	RS1-C-M6	HCC 001
M8	WEP 032	RS2-C-M8	
M10	WEP 045	RS2-C-M10	
M12	WEP 065	RS2-C-M12	
M16	WEP 115	RS2-C-M16	

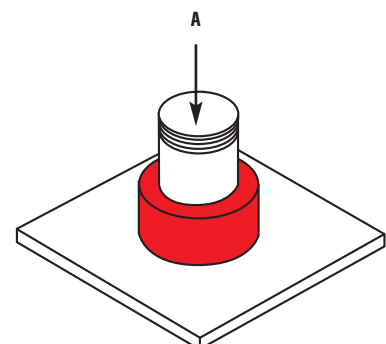

### Weld Powders

Part Number	Description	Box Quantity
WEP 025	25g Weld Powder	20
WEP 032	32g Weld Powder	
WEP 045	45g Weld Powder	
WEP 065	65g Weld Powder	
WEP 090	90g Weld Powder	10
WEP 115	115g Weld Powder	
WEP 150	150g Weld Powder	
WEP 200	200g Weld Powder	
WEP 250	250g Weld Powder	

Cu-nnect Weld Metal is a high quality mixture of copper oxide and aluminium, contained inside plastic cartridges which are packed in boxes of 10 or 20 pieces depending on the powder weight. The metal retaining discs are contained in a separate bag inside each box. Each weld connection uses one disc.

The starting powder is compacted at the bottom of each cartridge with the Weld Metal on top. The starting powder is released by firmly tapping the base of the cartridge.

Cu-nnect Weld Powder is not explosive, shock sensitive or subject to spontaneous ignition.



### Moulds

A semi-permanent graphite mould is used for making all Cu-nnect welded connections. Each mould is precision machined to control the flow of the molten Cu-nnect Weld Metal and the end shape of the connection. If used carefully and cleaned properly each mould will provide for approximately 75 connections.





## HANDLE CLAMPS, TOOLS & ACCESSORIES

### Handle Clamps

Part Number	Description
HCA 001	Small Handle Clamp
HCC 001	Medium Handle Clamp
HCC 002	Medium Handle Clamp with Vertical Chain Support
HCC 003	Medium Handle Clamp with Vertical Beam Support
HCC 004	Medium Handle Clamp with Horizontal Chain Support
HCD 001	Large Handle Clamp
HCD 002	Large Handle Clamp with Vertical Chain Support
HCD 003	Large Handle Clamp with Vertical Beam Support
HCD 004	Large Handle Clamp with Horizontal Chain Support

A Handle Clamp is required to hold the graphite mould and conductors in place whilst the connection is being made. Three sizes of Handle Clamp cover the range of connections shown in this catalogue.

Handle Clamps with a Chain Support are used to securely hold a Cu-nnect mould to either a Vertical or Horizontal pipe or reinforcement bar up to 4" in diameter.

Handle Clamps with a Beam Support are used to securely hold a Cu-nnect mould to a Vertical steel column or angle.



### Tools & Accessories

Part Number	Description
TCB 001	Tape Cleaning Brush
CCB 001	Cable Cleaning Brush
MCB 001	Mould Cleaning Brush
MCS 001	Mould Cleaning Scraper
FGN 001	Flint Gun
FLT 001	Replacement Flints
DSC 001	Disc Container
DXS 001	Duxseal Sealing Compound (1lb)
PAK 001	Ceramic Packing
BTT 001	Butane Torch
TBX 001	Welding Toolbox
CTK 001	Cu-nnect Toolkit for Bar Connections. Contains the following: Tape Cleaning Brush (TCB 001) Mould Cleaning Brush (MCB 001) Mould Cleaning Scraper (MCS 001) Flint Gun (FGN 001)
CTK 002	Cu-nnect Toolkit for Cable Connections. Contains the following: Tape Cleaning Brush (TCB 001) Cable Cleaning Brush (CCB 001) Mould Cleaning Brush (MCB 001) Mould Cleaning Scraper (MCS 001) Flint Gun (FGN 001)



A comprehensive range of tools and cleaning materials to aid your welding programme.

**PART NUMBER INDEX**

---

**B**

BB1 ..... 7  
BB14 ..... 9  
BB2 ..... 7  
BB3 ..... 8  
BB41 ..... 9  
BB7 ..... 8  
BR1 ..... 10  
BR2 ..... 11  
BS1 ..... 12  
BS2 ..... 12  
BS3 ..... 13  
BS4 ..... 13  
BTT 001 ..... 31

**C**

CB1 ..... 14  
CB4 ..... 15  
CB5 ..... 16  
CC1 ..... 17  
CC14 ..... 20  
CC2 ..... 17-18  
CC4 ..... 18  
CC7 ..... 19  
CCB 001 ..... 31  
CR1 ..... 21  
CR2 ..... 22  
CR3 ..... 23  
CRE1 ..... 24  
CRE17 ..... 26  
CRE2 ..... 24-25  
CRE3 ..... 25  
CRE6 ..... 26  
CS1 ..... 27  
CS2 ..... 27  
CS25 ..... 29  
CS27 ..... 29  
CS3 ..... 27  
CS7 ..... 28  
CS8 ..... 28  
CS9 ..... 28  
CTK 001 ..... 31  
CTK 002 ..... 32

**D**

DSC 001 ..... 31  
DXS 001 ..... 31

**F**

FGN 001 ..... 31  
FLT 001 ..... 31

**H**

HCA 001 ..... 31  
HCC 001 ..... 31  
HCC 002 ..... 31  
HCC 003 ..... 31  
HCC 004 ..... 31  
HCD 001 ..... 31  
HCD 002 ..... 31  
HCD 003 ..... 31  
HCD 004 ..... 31

**M**

MCB 001 ..... 31  
MCS 001 ..... 31

**P**

PAK 001 ..... 31

**R**

RS1 ..... 29  
RS2 ..... 29

**T**

TBX 001 ..... 31  
TCB 001 ..... 31

**W**

WEP 025 ..... 30  
WEP 032 ..... 30  
WEP 045 ..... 30  
WEP 065 ..... 30  
WEP 090 ..... 30  
WEP 115 ..... 30  
WEP 150 ..... 30  
WEP 200 ..... 30  
WEP 250 ..... 30

## CU-NNECT EXOTHERMIC WELDING

---

Designed and produced by McConnells Advertising & PR, Derby

**Copyright:** This brochure is Copyrighted to A. N. Wallis & Co. Ltd. Unauthorised reproduction or storage without permission is an infringement of that Copyright. Infringement of Copyright will result in legal actions. February 2005.

**Product Development:** It is A. N. Wallis's policy to continuously improve its products. Accordingly, A. N. Wallis reserves the right to amend product descriptions, specifications and performance without prior notice.



**A. N. WALLIS & Co. Ltd**

Greasley Street, Bulwell, Nottingham, East Midlands, NG6 8NG, United Kingdom

**Tel** +44 (0) 115 927 1721 • **Fax** +44 (0) 115 875 6630

**e-mail** [info@an-wallis.com](mailto:info@an-wallis.com) • **Website** [www.an-wallis.com](http://www.an-wallis.com)



FM 73972